



**Western Region Technical Attachment  
No. 93-14  
May 18, 1993**

**A REVIEW OF ISENTROPIC ANALYSIS  
WITH APPLICATIONS TO PCGRIDS**

**David Pike - WSFO Salt Lake City**

**Introduction**

With the increasing capabilities of today's computers, isentropic analysis has experienced a revival of interest over the past few years. Originally developed in the 1930s, isentropic analysis never became a popular operational tool due to the excessive amount of time required to perform the computations. Today, PCGRIDS has made it possible for the forecaster to have quick access to initial analysis and forecast isentropic surfaces. Isentropic analysis, although not a "stand alone" magic wand, can provide the forecaster with additional information that is not available from traditional pressure surface analyses. The objective of this Technical Attachment (TA) is to give a "theta eye view" of isentropic analysis by briefly giving some of the basics along with a few techniques that are available with PCGRIDS. Throughout the TA, commands for PCGRIDS are shown in brackets, such as [command].

**Description**

Isentropic analysis is primarily based on the first Law of Thermodynamics, which assumes adiabatic processes, where no exchange of heat occurs between an air parcel and the environment. The isentropic surface, or potential temperature surface, is calculated using Poisson's Equation:

$$\theta = T \left( \frac{1000}{P_o} \right)^\kappa \quad (\text{Eq. 1})$$

where  $\kappa = \frac{R}{C_p}$

Potential temperature ( $\theta$ ) is the temperature of an air parcel if it were compressed or expanded adiabatically from the original pressure,  $P_o$ , to 1000 mb. For synoptic scales of motion, and to some extent the sub-synoptic, air parcels will move along an isentropic surface making potential temperature a useful tracer of air parcels as well as a useful forecasting tool. Potential temperature is a conservative property in the absence of diabatic processes, which include solar and terrestrial radiation, latent heating, evaporative cooling, and mixing with environmental air of different thermodynamic properties or parcel entrainment. Typically, the adiabatic assumption will be violated in the vicinity of thunderstorms or areas of saturated conditions exist.

## Physics

The following sections will discuss four parameters: stability, vertical motion, convergence/divergence, and moisture. Each parameter will be defined in the isentropic framework, and an explanation of how to plot these parameters using PCGRIDS will also be included.

### 1. Stability

The atmosphere is, on average, stable. The environmental lapse rate, defined as  $-\delta T/\delta Z$ , is usually less than the dry adiabatic lapse rate ( $9.8 \text{ }^\circ\text{C km}^{-1}$ ). With respect to potential temperature, stability is then:

$$\frac{1}{\theta} \frac{\partial \theta}{\partial z} = \frac{\Gamma_d - \Gamma}{T} \quad (\text{Eq. 2})$$

Since the dry adiabatic lapse rate,  $\Gamma_d$ , is greater than or equal to the actual lapse rate  $\Gamma$  (except under super-adiabatic conditions) then for unsaturated air parcels,

$$\frac{\partial \theta}{\partial z} > 0 \text{ Stable}$$

$$\frac{\partial \theta}{\partial z} = 0 \text{ Neutral}$$

$$\frac{\partial \theta}{\partial z} < 0 \text{ Unstable}$$

Another way of viewing this would be to look at a sounding on either a Skew-T-Log P or Pseudo-Adiabatic chart. As the actual lapse rate approaches the dry adiabatic lapse rate (i.e., becoming more statically neutral), the change of potential temperature with height decreases, which implies that two consecutive isentropic surfaces will become farther apart in the vertical. Therefore, on a  $\theta$ -surface, areas of large pressure differences [PRES LDIF] would indicate which areas are more statically neutral (i.e., areas where vertical motion is more likely to occur given some type of forcing). It will be shown later that mass convergence in a layer decreases stability by forcing two potential temperature surfaces further apart. Likewise, the converse of this is true due to the conservation of mass between them.

An effective method of identifying these areas is through the use of a cross section [XSCT] of contoured isentropic surfaces [THTA CIN3] (Fig. 1). In the stratosphere, where temperatures increase with height (very stable conditions), the isentropic surfaces are closer together. Other features can also be seen on these cross-sections, such as the location of jets and upper-level fronts.

## 2. Vertical Motion

The vertical motion, with respect to pressure in isentropic coordinates, is given as :

$$\omega = \underbrace{\left(\frac{\partial P}{\partial t}\right)_{\theta}}_A + \underbrace{\vec{V} \cdot \nabla_{\theta} P}_B + \underbrace{\frac{\partial P}{\partial \theta} \frac{d\theta}{dt}}_C \quad (\text{Eq. 3})$$

Term A is the local pressure tendency which represents the movement of an isentropic surface at a point. On a given isentropic surface, this is plotted as a time differential change in pressure [PRES TDIF].

Term B is the advection of pressure on an isentropic surface and represented by the cross-isobar flow on that surface. This term generally is the most dominant of the three in synoptic situations. When the wind is plotted along with pressure [WIND/PRES CI25], areas where the wind is directed towards lower pressure (i.e., from 1000 mb to 500 mb) would indicate upward vertical motion (Fig. 2). The converse is also true for downward motion. A numerical value of this term is available using [PADV]. An alternative command available is [DOTP BKNT GRAD PRES], which calculates the vector dot product of the wind and the gradient of pressure.

Notice the area over Salt Lake City (Fig. 2) where the wind is directed from near 600 mb downward towards 800 mb. The tight gradient of isobars is a frontal zone where subsidence is occurring behind the front. In Fig. 3, the strongest upward motion is between 500 and 600 mb. Selecting a  $\theta$ -surface near 320K would highlight the area of maximum upward motion when viewed on a horizontal surface. Methods for selecting a  $\theta$ -surface will be discussed later.

Recalling equation 1, with  $\theta$  constant (an isentropic surface) and pressure constant (an isobar on the isentropic surface), it can be seen that temperature is also constant along an isobar. Therefore, areas of cross-isobar flow are also representative of thermal advection. Some caution should be used when looking at cross-isobar flow. Diurnal heating or cooling as well as strong latent heat release can cause  $\theta$ -surfaces to appear to move like a frontal surface especially if a  $\theta$ -surface is close to the ground. Even though there appears to be vertical motion in this area, the isentropic surface is also moving and, thus, may result in no motion. Vertical motion can still be inferred by assuming the wind velocity on the  $\theta$ -surface is greater than the movement of the  $\theta$ -surface itself. This assumption is valid under conditions when wind speeds increase with height, which is a normally accepted practice. Another solution would be to choose a temperature less susceptible to diurnal heating, or above the boundary layer.

The last term, C, incorporates the diabatic processes. For a stable atmosphere  $\theta$  increases as pressure decreases. therefore,  $\delta P / \delta \theta < 0$ . Thus, the sign of term C depends on  $d\theta/dt$ . This term, which is positive when heat is added ( $d\theta > 0$ ) over time, makes term C negative and thus  $\omega < 0$ . The net effect is to cause the parcel to shift to a different  $\theta$ -surface. Since the adiabatic assumption is violated, the air parcel is no longer moving along the original  $\theta$ -surface travel through the isentropic surface, maintaining the thermodynamic characteristics

associated with the parcel. This is one reason why caution must be used when looking at areas where condensation may be occurring.

### 3. Convergence and Divergence

Convergence in isentropic analysis requires some explanation as it is quite different than looking at convergence in pressure coordinates. In pressure coordinates, convergence and divergence are typically used to imply vertical motion. In isentropic coordinates, they are used to evaluate static stability through use of the continuity equation. As was already stated, the distance between two isentropic surfaces is a measure of static stability. Mass convergence within a layer forces the layers to spread apart, decreasing the static stability. In Fig. 4, the surfaces initially at  $\theta_a$  and  $\theta_1$  are displaced to  $\theta_b$  and  $\theta_2$ , respectively, forced apart due to mass convergence within that layer.

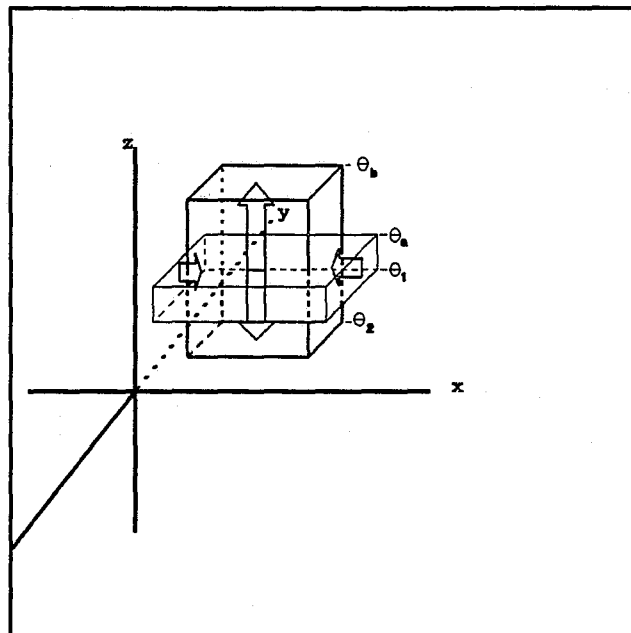

Fig. 4

### Moisture

An air parcel flows adiabatically along an isentropic surface, this is not true for a pressure surface. The mixing ratio of a parcel is conserved for adiabatic processes. Therefore, moisture fields will appear to be more continuous and easier to follow on an isentropic surface. Pockets of moisture will not suddenly appear in a following forecast period which can happen in pressure coordinates. Figure 5 shows how a parcel with a mixing ratio of  $7\text{g kg}^{-1}$  could appear suddenly at time  $t_1$  and then disappear at time  $t_2$  on a 700 mb surface. Yet on the 316K the original mixing ratio of the parcel is retained. Again, this is assuming adiabatic processes since problems arise in areas of saturation (i.e., in areas of latent heat release).

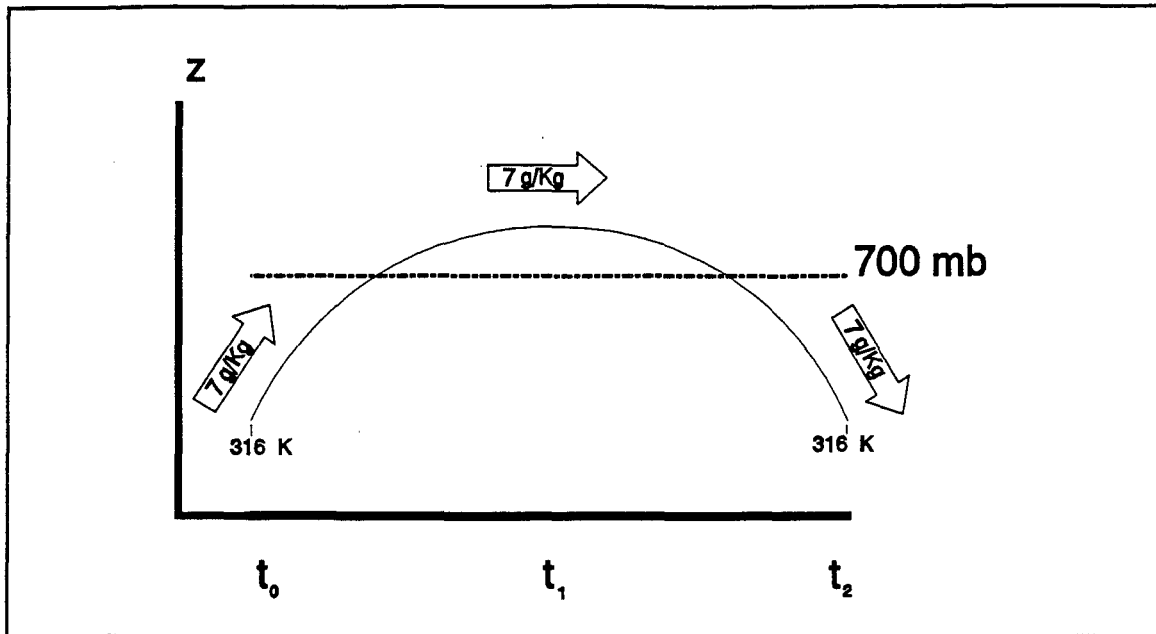

Fig. 5

### Selecting an Isentropic Surface

Usually, an isentropic analysis begins with a cross-sectional plot [XSCT] of potential temperature [THTA], wind [WIND], mixing ratio [MIXR], and vertical motion [VVEL] (a background of pressure [PRES] and latitude [LATT] or longitude [LONG] is also helpful). From the cross-section, select a set of isentropic surfaces which are: 1) in the vicinity of the features of interest; and 2) not intersecting the ground.

This process will help determine the isentropic levels to create [MTHT]. Usually an interval of 2K works well but even 5K would be sufficient. An isentropic surface is then selected [SLVL I300] and overlaid with the three parameters, pressure, wind, and mixing ratio [PRES CI20&WIND&MIXR]. From this, the vertical motion as well as moisture transport and other thermodynamic processes can be examined.

### Summary

Isentropic analysis provides additional information that may not be so obvious when looking at mandatory pressure levels. This may provide the necessary information a forecaster needs to finalize his/her decision on a difficult forecast. All analyses have their strong points and shortcomings which must be understood by the forecaster in order to best utilize them.

## References

Anderson, J., 1984: The Use and Interpretation of Isentropic Analyses, *NOAA Technical Memorandum NWS WR-188*, October 1984.

Moore, J. T., 1992: *Isentropic Analysis and Interpretation: Operational Applications to Synoptic and Mesoscale Forecast Problems*, St Louis University. (Available from the National Weather Service Training Center, Kansas City, Missouri.)

Osmun, J. W. W., 1937: An Introductory Discussion of the Isentropic Chart, United States Department of Agriculture Weather Bureau, Washington DC., October 1, 1937.

## PC-GRID COMMAND LIST

<b>CINX</b>	Contour interval...X = default value
<b>DOTP</b>	Calculates the dot product of 2 vectors.
<b>GRAD</b>	Calculates the gradient of a scalar to the right.
<b>LATT</b>	Latitude
<b>LONG</b>	Longitude
<b>MTHT</b>	Makes the isentropic surfaces. User prompted for top and bottom levels as well as level interval.
<b>MIXR</b>	Mixing ratio
<b>LDIF</b>	Calculates the layer difference of the quantities to the left.
<b>PADV</b>	Pressure advection
<b>PRES</b>	Pressure
<b>SLVL</b>	Sets the level of the analysis. Isentropic surfaces have an I preceding the temperature level.
<b>TDIF</b>	Time differential of quantities to the left of this command.
<b>THTA</b>	Potential temperature
<b>VVEL</b>	Vertical velocity
<b>WIND</b>	Wind arrows or barbs
<b>XSCT</b>	Calculates a cross-section. User inputs endpoints in latitude and longitude.

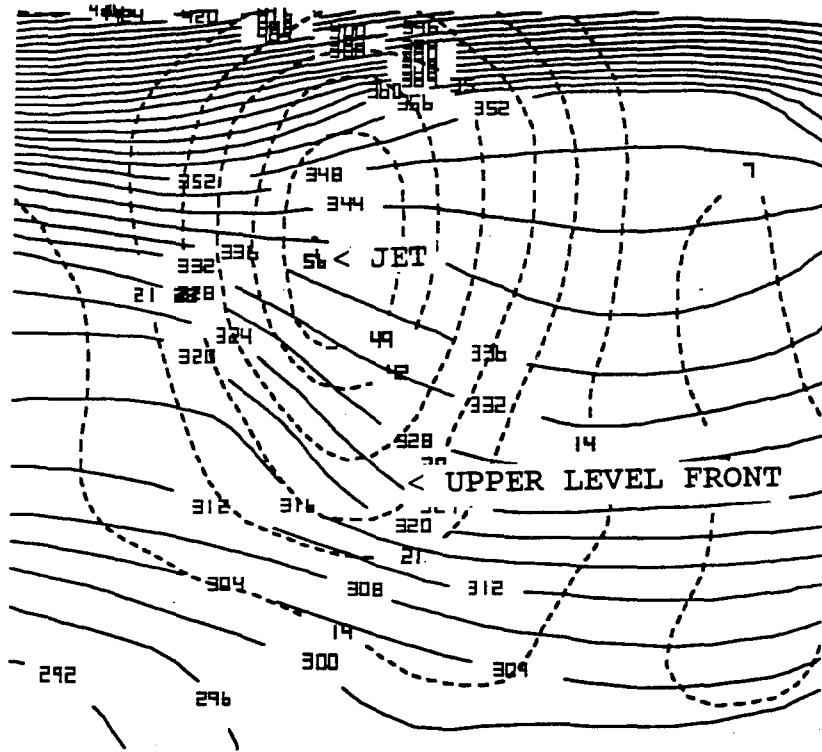

Fig. 1. Cross-sectional analysis of potential temperature (K) and magnitude of wind ( $m s^{-1}$ ).

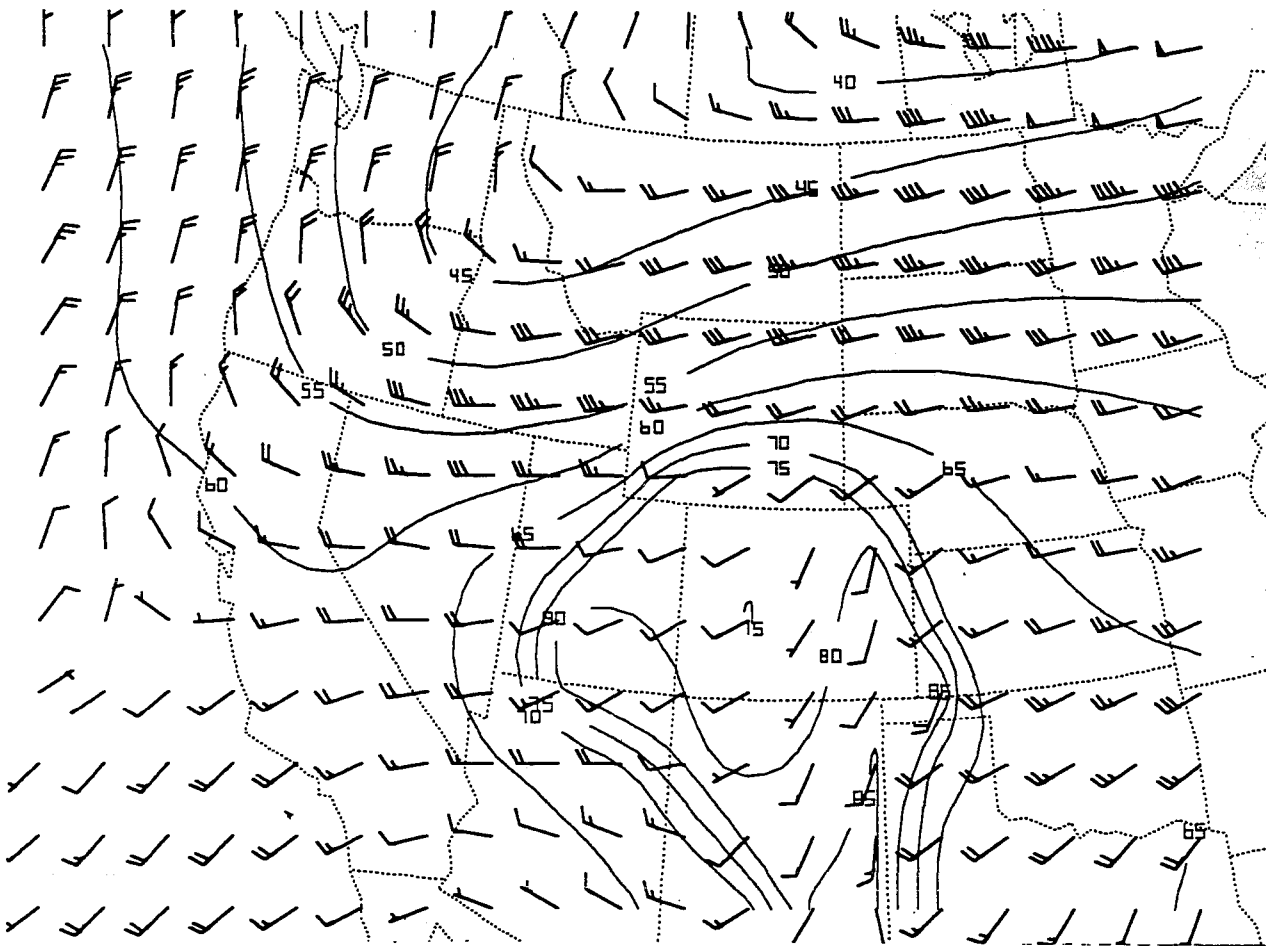

Fig. 2 316K isentropic surface with pressure (x10 mb) and wind (knots).

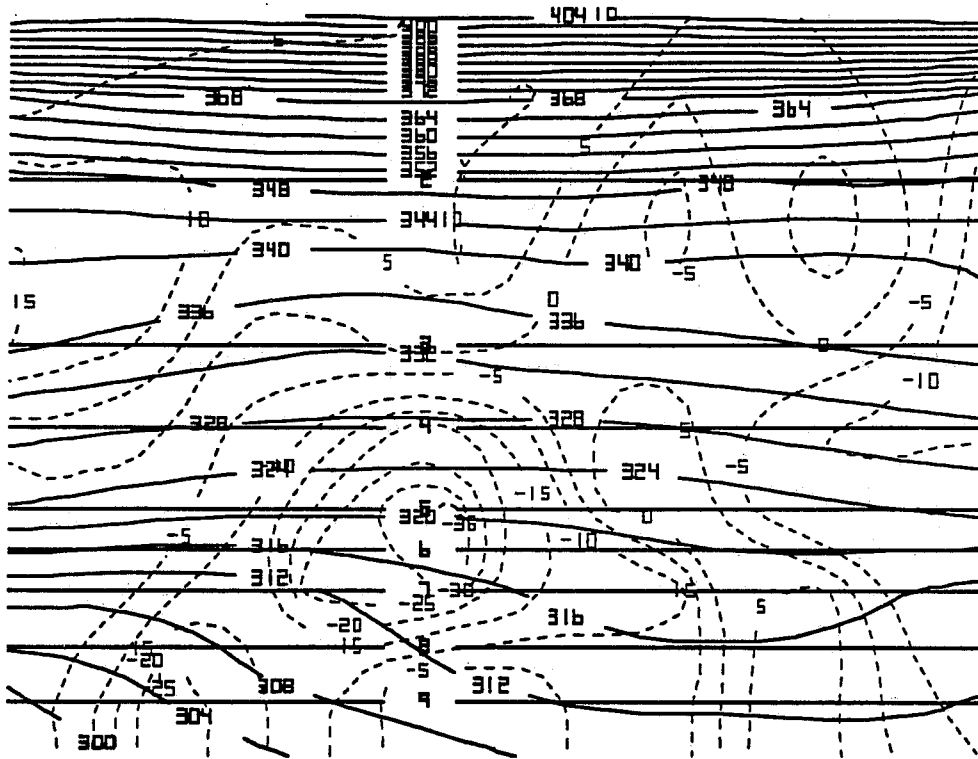

Fig. 3 Cross-sectional analysis of potential temperature (K, solid line), pressure ( $\times 10^2$  mb, solid line), and vertical velocity ( $\mu\text{b s}^{-1}$ , dashed line).